

#### IMPORTANT

#### **WARNING:**

1. LED Luminaire Retrofit Kit Including LED Tube, Installation instructions, Luminaire Marking Label.
2. Risk of fire or electric shock. LED Retrofit Kit installation requires knowledge of luminaires electrical systems. If not qualified, do not attempt installation. Contact a qualified electrician in accordance with the National Electrical Code and relevant local code. 0-10V / Phase cut dimming with specified dimmers only.
3. Risk of fire or electric shock. Install this kit only in the luminaires that have the construction features and dimensions shown in the photographs and/or drawings and where the input rating of the retrofit kit does not exceed the input rating of the luminaire.
4. To prevent wiring damage or abrasion, do not expose wiring to edges of sheet metal or other sharp objects. Do not make or alter any open holes in an enclosure of wiring or electrical components during kit installation. This device is not intended for use with emergency exits. This item is rated at 120-277V. Installer must determine whether line voltage 120-277V is available at the luminaire before installation.

#### SUITABLE FOR DAMP LOCATIONS.

5. Installers should not disconnect existing wires from lampholder terminals to make new connections at lampholder terminals. Instead installers should cut existing lampholder leads away from the lampholder and make new electrical connections to lampholder lead wires by employing applicable connectors.
6. THIS RETROFIT KIT IS ACCEPTED AS A COMPONENT OF A LUMINAIRE WHERE THE SUITABILITY OF THE COMBINATION SHALL BE DETERMINED BY AUTHORITIES HAVING JURISDICTION.
7. To avoid potential fire or shock hazard, do not use this retrofit kit in luminaires employing shunted bi-pin lampholders when the lamp is energized at the single end. Note: Shunted lamp holders are found only in fluorescent luminaires with Instant-Start ballasts. Instant-start ballasts can be identified by the words "Instant Start" or "I.S." marked on the ballast. This designation may be in the form of a statement pertaining to the ballast itself, or may be combined with the marking for the lamps with which the ballast is intended to be used, for example F40T12/1S. For more information, contact the LED luminaire retrofit kit manufacturer.

#### **Safety Precautions :**

For your and others' safety, please read the precaution carefully before installation:

- (1). Product should be installed by qualified electrician.
- (2). Switch off the power supply before commencing work, make sure correct connection before power on.

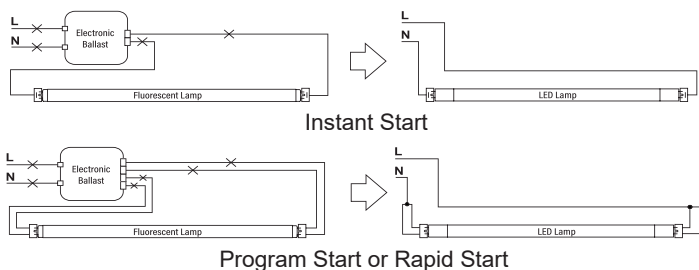
#### INSTALLATION INSTRUCTIONS—Ballast Bypass DOUBLE-ENDED POWER—Type B

1. Make sure the circuit breaker that supplies the power to the fixture is turned off.
2. Remove lens or diffuser cover (if applicable) and existing fluorescent lamps.
3. Open/Remove ballast wiring compartment cover.
4. Identify the line and neutral wires running from the breaker box to the ballast and confirm the power is off using a voltmeter.
5. Cut all wires connected to ballast, Dispose of removed ballast and fluorescent lamps in accordance with government regulations in your area.
6. Ensure that the fixture contains shunted G13 bi-pin lamp holders. If socket lamp holders are non-shunted, replace with new shunted socket lamp holders, or shunted with a jumper wire to convert into shunted sockets.
7. LED T8 lamps are designed for double sided connections only (Fig. 1). To install, please wire non-shunted sockets by connecting one wire from the lamp holder to branch circuit L (LIVE) and the other wire at the opposite end to branch circuit N (NEUTRAL). Do not connect opposite side to power. Use appropriate wires for connection.

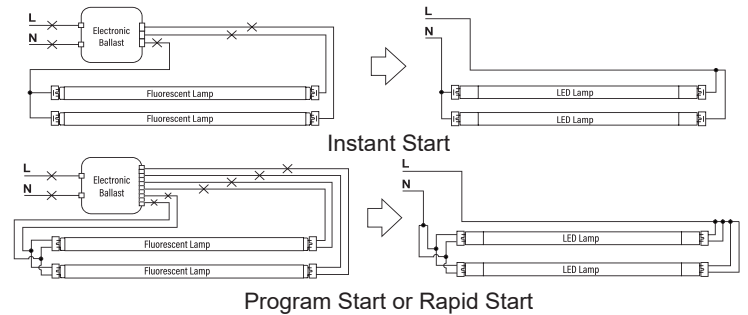


**Fig. 1** - Double sided connections

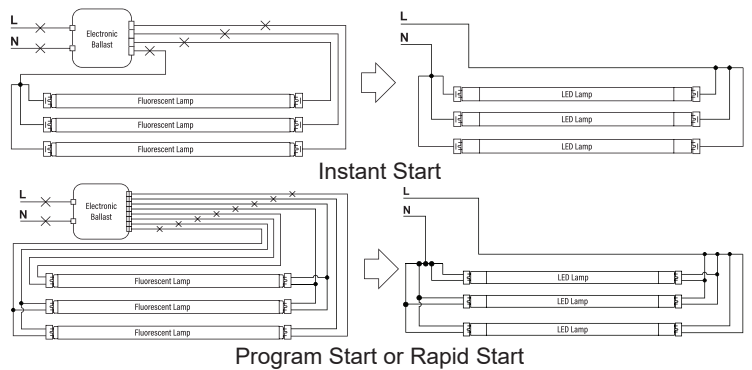
8. Make sure all sockets are replaced and wired according to the appropriate wiring diagram. (Fig. 2, 3, 4, 5).



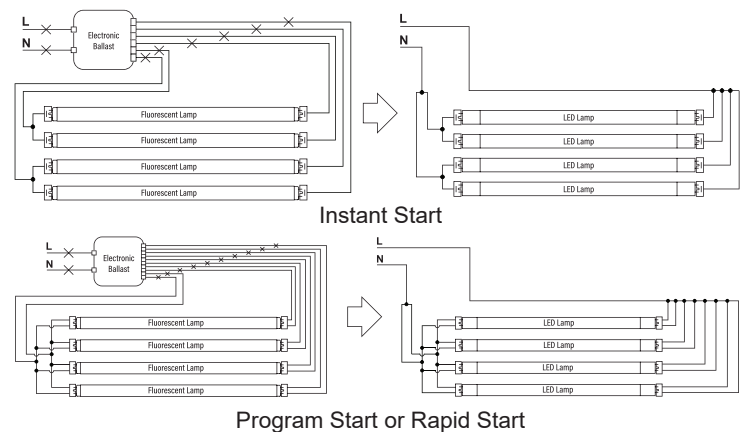
**Fig. 2** - Retrofit luminaire with One Lamp



**Fig. 3** - Retrofit luminaire with Two Lamps



**Fig. 4** - Retrofit luminaire with Three Lamps



**Fig. 5** - Retrofit luminaire with Four Lamps

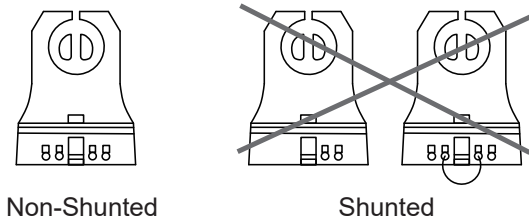
9. Reinstall the ballast cover to hide all wires.
10. Install your new LED T8 replacement lamps.
11. Apply Relamping Label on a visible location inside the fixture.
12. Reinstall lens or diffusion cover on the light fixture.
13. Turn power on at the breaker box.
14. Turn on the lights.

*Note: These instructions do not cover all details or variations in equipment nor do they provide for every possible situation during installation, operation or maintenance.*

#### INSTALLATION INSTRUCTIONS—Ballast Bypass SINGLE-ENDED POWER—Type B

---

1. Turn Power OFF.
2. If applicable, replace lamp holders at power end with non-shunted lamp holders (Fig.6).



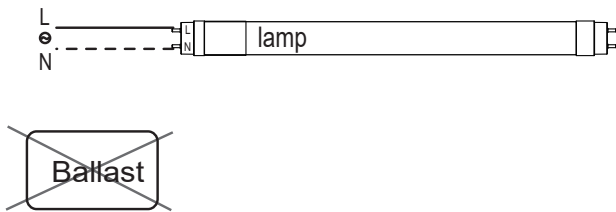
**Fig: 6**

3. Install lamp with the L and N markings into the wired lamp holder end (Fig.7).

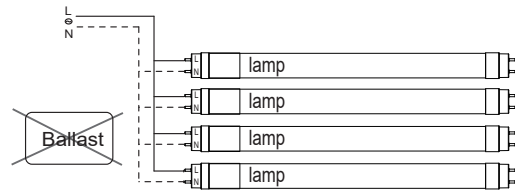


**Fig: 7**

4. If installing a single tube refer to Fig. 8. If connecting multiple lamps, connect separate neutral wire into "Neutral out" from primary source lamp holder and connect that wire into "Neutral in" on the adjacent tube. See Fig. 9 below.



**Fig: 8**



**Fig: 9**

**Address: 755 E. Ellis Rd.  
 Norton Shores, MI 49441  
 Phone: +1-866-632-7840  
 Fax : +1-231-726-5029  
 Email: [contact@earthtronics.com](mailto:contact@earthtronics.com)  
 Web: [www.earthtronics.com](http://www.earthtronics.com)**