

Project	
Date	
Prepared By	
Model #	HBL510550WH5

## Specifications

### ELECTRICAL

**Watts:** 105  
**Voltage:** 120-347VAC  
**Power Factor:** >0.9  
**THD:** 10%  
**Operating Temp. Range:**  
 -20°C (-4°F) to 50°C (122°F)

### LIGHT

**Initial Lumens:** 14175  
**Lumens per Watt:** 135  
**Color Temperature:** 5000K  
**CRI:** 82  
**Dimming:** 0-10V

### AGENCY APPROVALS

**DLC® Premium:** Yes  
**UL:** Yes  
**RoHS:** Yes

### PRODUCT DETAILS

**Lens:** Acrylic  
**Warranty:** 5 years  
**Fixture**  
**Rated Life:** 50,000 hours  
**Lumen Maintenance:**  
 L95 at 50,000 hrs (68°C)  
**Weight:** 10.12 LBS  
**Dimensions:**  
 24.8"L x 15"W x 2.2"D

# Linear LED Highbay 24"

14175 Lumens, 105 Watt, 5000K



**ORDER CODE:**  
 11522

**MODEL NUMBER:**  
 HBL510550WH5

**DLC PRODUCT ID:**  
 PE821C0R

**REBATE AVAILABILITY\***

### PRODUCT DESCRIPTION

EarthTronics LED Highbay offers a lightweight slim design that delivers excellent energy efficiency. This highbay is designed to accept an optional an integrated microwave sensor capable of providing daylight harvesting, step dimming and motion sensitivity to maximize energy savings. This 105 watt fixture has a 24" design and produces 14175 lumens which is suitable for 10-30' mounting heights. It features 5000K color temperature with a high 80+ CRI providing excellent visual acuity for accuracy when working in manufacturing and warehousing applications. High quality Seoul LED chips provide for excellent lumen maintenance. L95 is at 50,000 hours and L80 at 120,000 hours (68°C). Sensors are available. DLC® Premium listed.

### PRODUCT FEATURES

- + 120-347VAC 50-60Hz
- + 5000K color temperature with 80 CRI+
- + DLC® Technical Requirement 5.1
- + Extended 10 year limited warranty available
- + Operating at 135 lumens per watt
- + Driver standard with 0-10V dimming (prewired)
- + 6' 300V 18/3 SJT whip, V-hooks & chain included
- + Continuous Dimming above 10%
- + Rated for damp location

### APPLICATIONS

- + Warehouse
- + Auditorium
- + Manufacturing Facility
- + Gymnasium
- + Cafeteria

## PRODUCT DIMENSIONS

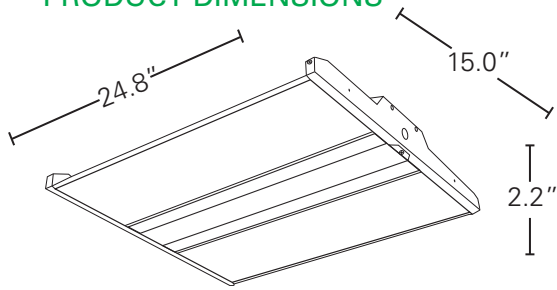

## PACKAGE DETAILS

### Dimensions:

25.55" Length x 15.31" Width x 2.99" Depth

Weight: 11.22 LBS

UPC: 840791115220

## LIGHT DISTRIBUTION CURVE

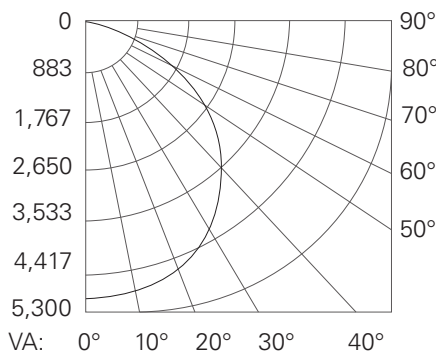

## LIGHTING LAYOUT

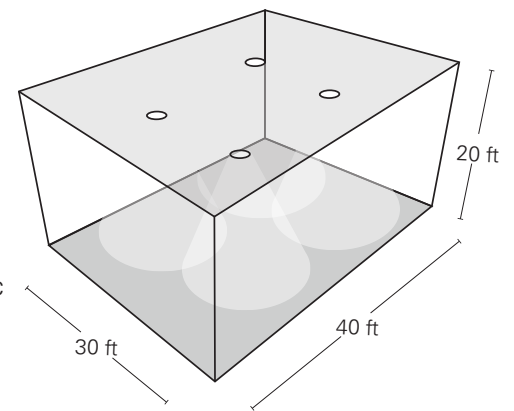

Average Illuminance: 26 fc

Number of Luminaires: 4

Workplane Height: 2.5 ft

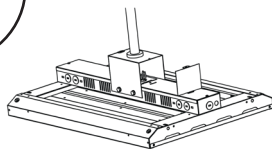

**Pendant Hanger**  
Order Code: 11384

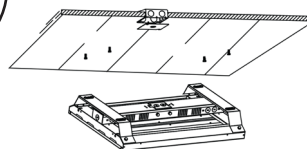
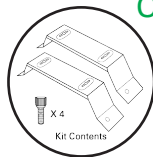

**Surface Mount**  
Order Code: 11388

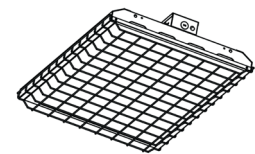

**Wire Guard**  
Order Code: 11385



**Remote Control for Sensor**  
Order Code: 11282



**Microwave Sensor**  
Order Code: 11281

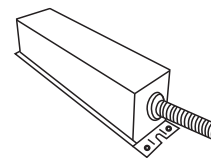

**External Emergency Back up Kit**  
Order Code: HBLEMKIT

Easily access our DLC qualified products with rebates in your area.

ACCESS IT HERE: [Rebate Finder - Highbay Linear](#)

[www.earthtronics.com/rebate-finder/catalog/](http://www.earthtronics.com/rebate-finder/catalog/)

