

LED 2x2 Panel

LED Flat Panel 2x2 40 Watt 4000 Lumens 4000K



Product Description

The 2x2 LED Panel light is constructed using an extruded aluminum frame with a high quality PMMA light distribution panel combined with an attractive acrylic lens that achieves a wide light distribution pattern. The use of PMMA assures that the LED light panel will not yellow over time. EarthTronics guarantees the lens against yellowing for the life of product.

This 2x2 panel features 120/277V dual voltage operation and is equipped standard with a 0 - 10 Volt continuous dimming driver that works with any standard 0 - 10 Volt control/dimmer. The 3500K light and high 82+CRI provides a bright white light solution.

These Panel lights are ideal for use in offices, schools, healthcare, and many other commercial applications. IC Rated.

LED Panels feature

- Solid construction frame is suitable for pendant mounting.
- Earthquake clips are standard on each panel light.
- 120-277VAC operation with 0-10V dimming is standard.
- PMMA light distribution panel evenly distributes the light across the face of the panel and does not yellow over time.
- Acrylic lens provides an attractive appearance and wide light distribution.
- Emergency back-up driver system is available, contact EarthTronics for details.

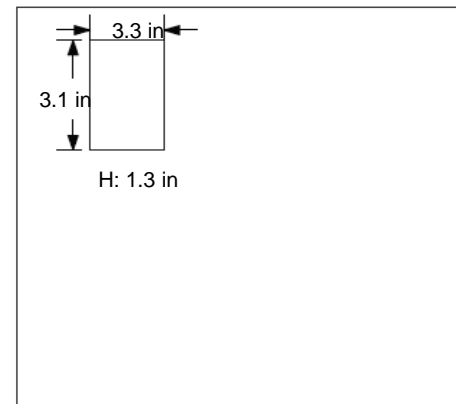
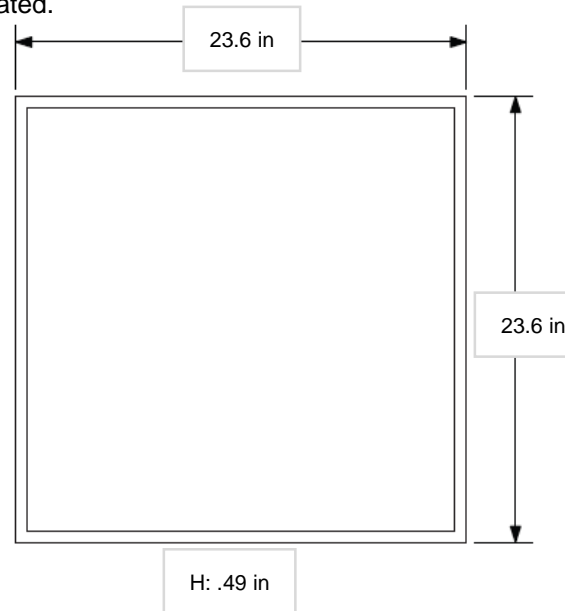

Order Code: 10548 – 2pk
10546 – 1pk

- **Important ordering note:** Please order in 2-packs. Only order single packs when an odd number of Panel Lights is required on a job site.

DLC Product ID: P45EJRN

Model: L3FP2X24040D

Accessories (Ordered Separately)

- Surface Mount Kits 2x2 – Order Code: 10458
- Wire Hanger Kit 2x2 - Order Code: 10465

Electrical

Watt	40
Voltage	120-277V
Min. Start Temperature	-40°C
Max. Operating Temperature	40°C
Driver Type	Class2
Driver Output	27-42V Direct Current
Dimming	0 – 10 Volt

Light

Initial Lumens	4000
Lumens per Watt	100
Color Temperature	4000K
Color Rendering (CRI)	80
Beam Angle	110°

Agency Approvals

DLC	Yes
FCC	Yes
ETL	Yes

Product Details

Housing Material	Extruded Aluminum
Lens Material	Acrylic
Warranty	5 years
Rated Life	50,000 hours

