

Project	
Date	
Prepared By	
Model#	LTF2X2WSCCTSD5

Specifications

ELECTRICAL

Watts: 18W/26W/35W

Voltage: 120-347V

Power Factor: 0.9

Operating Temp. Range:
-20°C - 45°C

LIGHT

Initial Lumens:

2200LM/3300LM/4400LM

Lumens per Watt: 125

Color Temperature:

3500K, 4000K, 5000K

Ra: >80

Dimming: 0-10V Dimming

Beam Angle: 120°

AGENCY APPROVALS

DLC: Premium

UL1598: Yes

UL8750: Yes

FCC: Yes

PRODUCT DETAILS

Finish: White

Diffuser: PMMA

Trim: Aluminum

Housing: SPCC

Warranty: 5 Years

Fixture Rated Life: 36000
Hours

LED 2x2 Troffer

Color & Wattage Selectable



ORDER CODE: 11971

MODEL NUMBER:
LTF2X2WSCCTSD5

WATTS: 18W/26W/35W

COLOR TEMPERATURE:
3500K, 4000K, 5000K

LUMENS: 2200LM/3300LM/
4400LM

DLC® PREMIUM:
REBATE AVAILABILITY*

PRODUCT DESCRIPTION

The 2x2 Troffer Center Basket LED fixture is a high-performance, energy-efficient lighting solution designed for commercial and office environments. Featuring DLC Premium certification, it offers selectable wattage options (35W, 26W, 18W) with lumen outputs up to 5500 lumens at 125 lm/W, ensuring versatility and efficiency. Its 0-10V dimming with dim-to-off functionality allows seamless integration into lighting control systems, while the durable aluminum housing and PMMA diffuser provide uniform illumination. Designed for damp locations, this fixture is ideal for offices, schools, and retail spaces, boasting a high CRI (>80) for accurate color rendering. With a long lifespan of 36,000 hours at L90, a 5-year warranty, and compliance with UL1598, UL8750, DLC 5.1, and FCC Part 15B standards, it ensures reliability and reduced maintenance costs. Optional sensor modules further enhance control and energy savings, making it a smart choice for any commercial lighting upgrade.

PRODUCT FEATURES

- + Color selectable: 3500K, 4000K, 5000K
- + Wattage selectable: 18, 26, 35
- + Standard 120-347V
- + 0-10V continuous dimming driver
- + Dimming range of 10% to 100%
- + DLC® Premium

APPLICATION

- + Office
- + Healthcare Facilities
- + New Construction
- + Commercial
- + Industrial



EarthTronics

LED 2x2 Troffer

Color & Wattage Selectable

PRODUCT DIMENSIONS

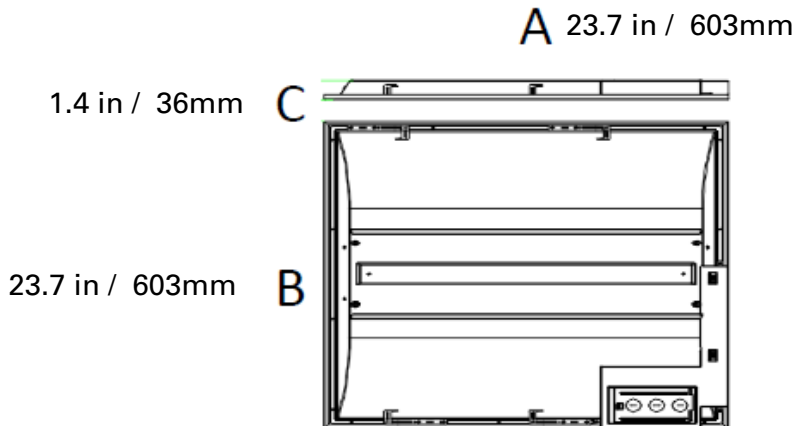

PACKAGE DETAILS

INDIVIDUAL PACKAGE

Individual Carton Qty: 1
Dimensions: 23.7in x 1.4in x 23.7in
Weight: 3.9 lbs
UPC: 840791119716

MASTER CARTON

Master Carton Qty:
Dimensions:
Weight:
UPC: 84079111971600

OPTIONAL ACCESSORIES

Easily access our DLC qualified products with rebates in your area.

ACCESS IT HERE: [Rebate Finder - LED Troffers](#)

www.earthtronics.com/rebate-finder/catalog/

EarthTronics, Inc. | Norton Shores, MI 49441 | www.earthtronics.com | Email: contact@earthtronics.com

Toll Free: 866.632.7840



Rev. 2.18.25 | 11971