

Project	
Date	
Prepared By	
Model #	LDFP2X2WSCCTD1

Specifications

ELECTRICAL

Watts: 20, 30 or 35

Voltage: 120-277VAC

Power Factor: 0.9113

THD: 7.86%

Operating Temp. Range:
-40°C (-40°F) - 40°C (104°F)

LIGHT

Lumens:

2200, 3300 or 4000

Color Temperature:

3500K, 4000K, 5000K

CRI: 80+

Driver: 0-10V

Operation: Dimmable
down to 10%

AGENCY APPROVALS

ETL: Yes

UL: Conforms to Std 1598

FCC: Yes

IC Rated: Yes

DLC®: Yes

PRODUCT DETAILS

Lens Material: Acrylic

Rated Life: 50,000 hrs.

Warranty: 5 years

Individual Weight: 3.8

LBS

Dimensions:

23.62" Length

23.62" Width

1.55" Depth

Back Light LED Panel 2x2

Color and Wattage Selectable

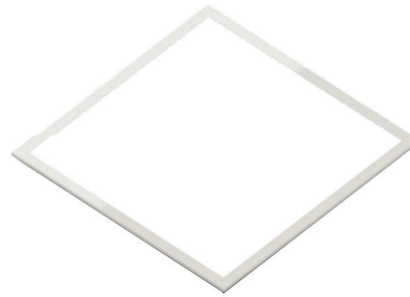

ORDER CODE:

11496

MODEL NUMBER:

LDFP2X2WSCCTD1

COLOR SELECTABLE:

3500K, 4000K, 5000K

LUMEN LEVEL:

2200 lumens - 20 watts

3300 lumens - 30 watts

4000 lumens - 35 watts

DLC PRODUCT ID:

PL8ZXRZQ08DG

PRODUCT DESCRIPTION

This 2x2 LED back light design provides the flexibility to insure the correct light level and color temperature desired in different applications. Select from 3500K, 4000K or 5000K color temperatures as well as 2200, 3300 or 4000 lumen levels with a switch located on the driver housing. The lightweight housing and slim design, measures only 1.5 inches in depth. The integral j-box and driver housing provide ample access for easy installation. The fixture is constructed using stamped steel back plate that provides excellent LED cooling as well as contributing rigidity to the design. The interior of the fixture is highly reflective white powder coated. The direct illumination panel is ideal for use in offices, schools, healthcare facilities and other commercial applications. This 2x2 panel features 120-277V voltage operation with an electronic driver that works with 0 – 10 volt dimming systems. DLC® listed.

PRODUCT FEATURES

- + Select from 3500K, 4000K and 5000K at installation with a simple switch located on the driver
- + Direct illumination provides true color over the life of the product
- + Driver standard with 0-10V dimming (prewired)
- + Fixture interior painted white for over 96% reflectivity
- + Continuous dimming to 10% or below
- + Contractor friendly box for easy installation
- + Aluminum fram fits properly in drop ceiling panels
- + Extended 10 year limited warranty available
- + Integral LED lens is constructed from PMMA and provides even illumination across the face of the panel
- + DLC® Technical Requirement 5.1

APPLICATIONS

- + Offices
- + Schools
- + Healthcare Facilities
- + Commercial Applications

Please consult installation instructions for proper application and use of this fixture.

*

PRODUCT DIMENSIONS

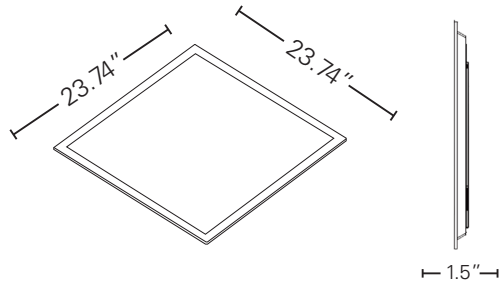

PACKAGE DETAILS

Master Carton Qty: 2

Dimensions:

24.65" Length x 25.75" Width x 3.67" Depth

Weight: 9.4 LBS

UPC: 840791116739

LIGHT DISTRIBUTION CURVE

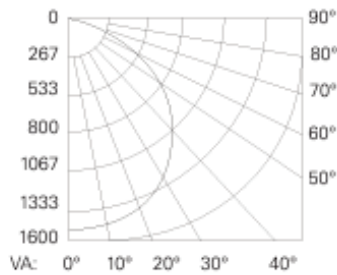

LIGHTING LAYOUT

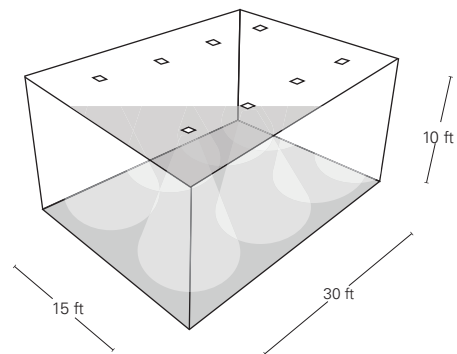

Average Illuminance: 50 fc

Number of Luminaires: 8

Workplane Height: 2.5 ft

OPTIONAL ACCESSORIES

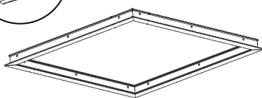

Recessed Drywall Kit
Order Code: 11101

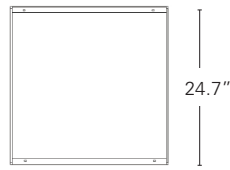

Surface Mount
Order Code: 11530



External Emergency Backup Unit
Order Code: 11469



EarthConnect
Bluetooth® Mesh
Fixture Controller
Order Code: 11799



EarthConnect
Non- Bluetooth® Mesh
Fixture Controller
Order Code: 11800



EarthConnect
Bluetooth® Mesh PIR
Sensor 12V DC
Order Code: 11801

* Wire Hanging Kit Available - Order code: 10465

